

# Model: DC-436

Extruded Aluminum Louver - Mounting Option #1 Shown

Miami-Dade County, FL  
NOA No: 07-1105.04  
Expiration Date: 2/07/2013

## Application:

DC-436 is an extruded louver designed specifically to meet the following Miami-Dade County test requirements and protocols:

- **TAS 201-94** (Large Missile Impact Test)
- **TAS 202-94** (Uniform Static Air Pressure Test)
- **TAS 203-94** (Cycle Wind Loading Test)

Based on single section testing of an 84"w x 120"h sample with a maximum design load pressure of 120-psf.

## Standard Specifications:

**Frame:** Heavy gauge 4" x .080" thick 6063T5 extruded aluminum.

**Blade:** Drainable design .080" thick 6063T5 extruded aluminum, mechanically fastened and welded to jambs on backside of blade, set on 36 degree angles. (Bottom blade opening varies).

**Birdscreen:** Standard .0516" x 3/4" flattened expanded aluminum.

**Anchor Clips:** 2" x 2" x 3/16" x 2" long.

### Minimum size:

8"w X 8"h

### Maximum Size:

84"w x 120"h Single Section.  
Unlimited width x 120"h sectional.

## Options:

- Insect Screen
- Approved Wedge Anchors
- Mill Finish (standard)
- Enamel Finish
- Kynar Finish
- Anodized Finish
- Powder Coating (Other Finishes Available)

## Features:

- Louver may be used in approved masonry or wood structure walls
- 58% Free Area
- Published performance ratings based on testing in accordance with AMCA Standard 500-L

Note: All DC-436 louvers are built 1/2" under size both directions unless ordered actual size.

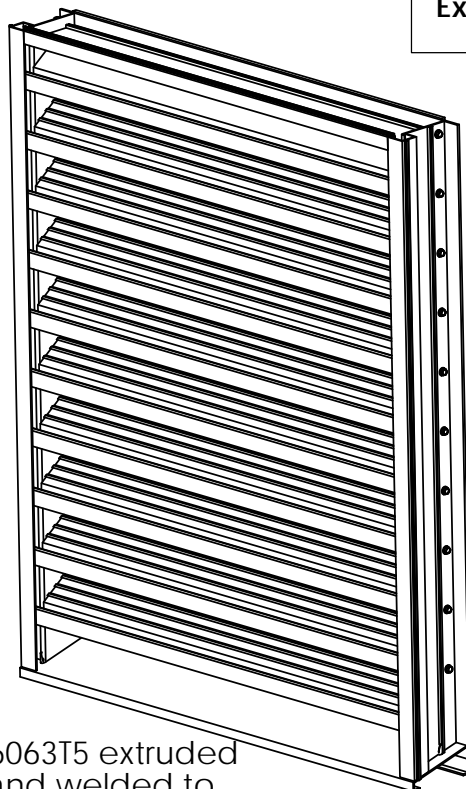

Max Wind Load  
+/- 120 psf

## Mounting Option #1

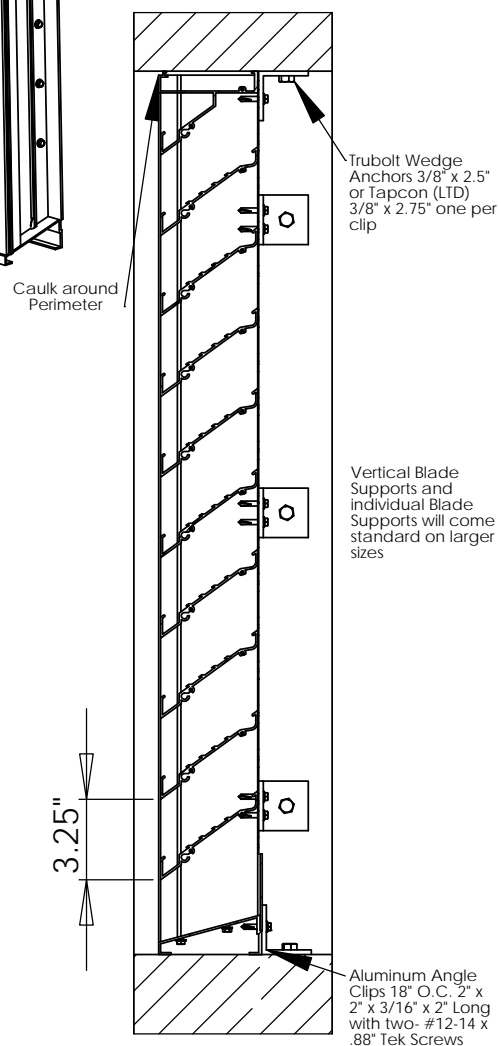

**58% Free Area**

**LEADER**  
Dampers & Louvers

P.O. Box 40913  
Nashville, TN 37204  
www.leaderindustries.com  
A Division of Leader Industries, Inc.



# Free Area Chart For DC-436

Width in Inches

	12.00	18.00	24.00	30.00	36.00	42.00	48.00	54.00	60.00	66.00	72.00	78.00	84.00	
H E I G H T  I N C H E S	12	0.39	0.63	0.87	1.12	1.36	1.61	1.85	2.09	2.34	2.58	2.82	3.07	3.31
	18	0.67	1.10	1.52	1.94	2.37	2.79	3.21	3.64	4.06	4.49	4.91	5.33	5.76
	24	0.93	1.51	2.10	2.68	3.27	3.85	4.44	5.02	5.61	6.20	6.78	7.37	7.95
	30	1.18	1.93	2.67	3.41	4.16	4.90	5.65	6.39	7.14	7.88	8.62	9.37	10.11
	36	1.43	2.34	3.24	4.14	5.05	5.95	6.85	7.76	8.66	9.57	10.47	11.37	12.28
	42	1.67	2.73	3.78	4.83	5.89	6.94	7.99	9.05	10.10	11.16	12.21	13.26	14.32
	48	1.94	3.16	4.39	5.61	6.83	8.05	9.28	10.50	11.72	12.95	14.17	15.39	16.62
	54	2.24	3.66	5.07	6.48	7.90	9.31	10.73	12.14	13.55	14.97	16.38	17.79	19.21
	60	2.52	4.10	5.69	7.27	8.86	10.44	12.03	13.62	15.20	16.79	18.37	19.96	21.54
	66	2.77	4.51	6.26	8.00	9.75	11.49	13.24	14.98	16.73	18.47	20.22	21.96	23.71
	72	3.02	4.92	6.83	8.73	10.64	12.54	14.44	16.35	18.25	20.16	22.06	23.96	25.87
	78	3.24	5.29	7.33	9.37	11.42	13.46	15.51	17.55	19.59	21.64	23.68	25.72	27.77
	84	3.53	5.75	7.98	10.20	12.42	14.65	16.87	19.09	21.32	23.54	25.77	27.99	30.21
	90	3.81	6.22	8.62	11.03	13.43	15.83	18.24	20.64	23.04	25.45	27.85	30.26	32.66
	96	4.10	6.68	9.27	11.85	14.43	17.02	19.60	22.19	24.77	27.35	29.94	32.52	35.10
	102	4.36	7.10	9.85	12.59	15.34	18.08	20.83	23.57	26.32	29.06	31.81	34.55	37.30
108	4.61	7.51	10.42	13.32	16.23	19.13	22.03	24.94	27.84	30.75	33.65	36.56	39.46	
114	4.86	7.92	10.99	14.05	17.11	20.18	23.24	26.31	29.37	32.43	35.50	38.56	41.62	
120	5.10	8.31	11.53	14.74	17.95	21.17	24.38	27.60	30.81	34.02	37.24	40.45	43.66	



Leader Industries Inc. certifies that the Model DC-436 - Horizontal Blade Louver shown herein is licensed to bear the AMCA Seal. The ratings shown are based on tests and procedures performed in accordance with AMCA Publication 511 and comply with the requirements of the AMCA Certified Ratings Program. The AMCA Certified Ratings Seal applies to air performance and water penetration ratings.

Water Penetration

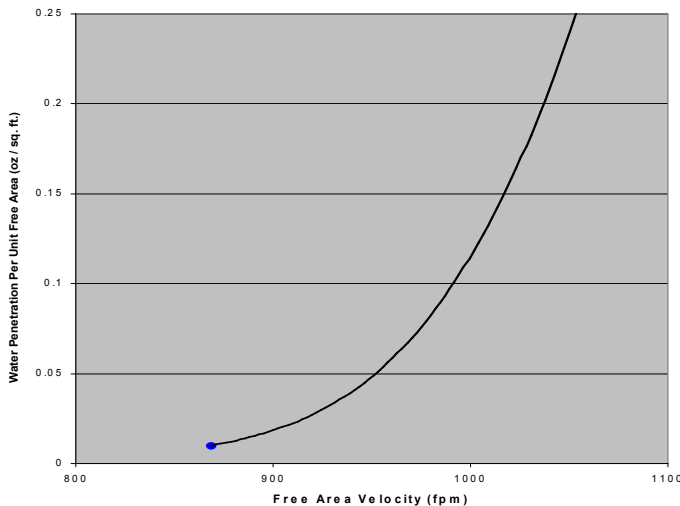

Beginning of water penetration per AMCA Publication 511 Subsection C3.2 based on AMCA measured free area: 868.8 fpm. Test duration was 15 min and test size was 48" x 48".

Airflow Resistance

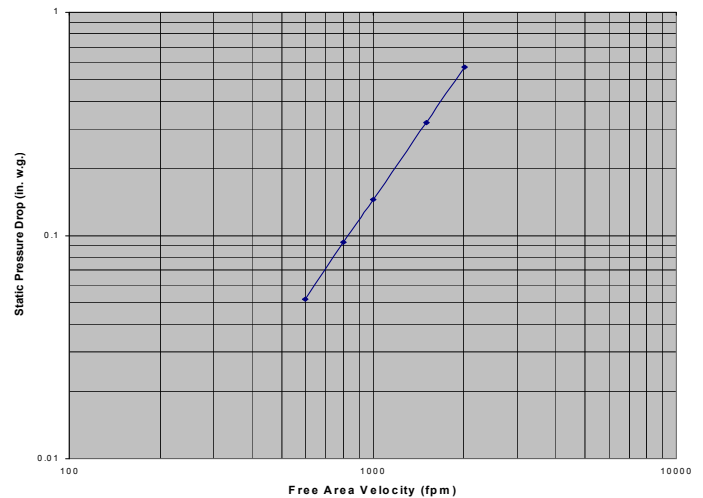

The performance shown is done at standard air density, 0.075lbs./ft. The pressure drop data applies to the intake side of the test unit that was 48" x 48" only.



P.O. Box 40913  
Nashville, TN 37204  
www.leaderindustries.com  
A Division of Leader Industries, Inc.

# Model DC-436 Extruded Aluminum Louver

## CFM and Free Area Selection Chart

		Louver Width (in.)												
		12	18	24	30	36	42	48	54	60	66	72	78	84
Louver Height (in.)	12	0.39 293	0.63 473	0.87 653	1.12 840	1.36 1020	1.61 1208	1.85 1388	2.09 1568	2.34 1755	2.58 1935	2.82 2115	3.07 2303	3.31 2483
	18	0.67 503	1.10 825	1.52 1140	1.94 1455	2.37 1778	2.79 2093	3.21 2408	3.64 2730	4.06 3045	4.49 3368	4.91 3683	5.33 3998	5.76 4320
	24	0.93 698	1.51 1133	2.10 1575	2.68 2010	3.27 2453	3.85 2888	4.44 3330	5.02 3765	5.61 4208	6.20 4650	6.78 5085	7.37 5528	7.95 5963
	30	1.18 885	1.93 1448	2.67 2003	3.41 2558	4.16 3120	4.90 3675	5.65 4238	6.39 4793	7.14 5355	7.88 5910	8.62 6465	9.37 7028	10.11 7583
	36	1.43 1073	2.34 1755	3.24 2430	4.14 3105	5.05 3788	5.95 4463	6.85 5138	7.76 5820	8.66 6495	9.57 7178	10.47 7853	11.37 8528	12.28 9210
	42	1.67 1253	2.73 2048	3.78 2835	4.83 3623	5.89 4418	6.94 5205	7.99 5993	9.05 6788	10.10 7575	11.16 8370	12.21 9158	13.26 9945	14.32 10740
	48	1.94 1455	3.16 2370	4.39 3293	5.61 4208	6.83 5123	8.05 6038	9.28 6960	10.50 7875	11.72 8790	12.95 9713	14.17 10628	15.39 11543	16.62 12465
	54	2.24 1680	3.66 2745	5.07 3803	6.48 4860	7.90 5925	9.31 6983	10.73 8048	12.14 9105	13.55 10163	14.97 11228	16.38 12285	17.79 13343	19.21 14408
	60	2.52 1890	4.10 3075	5.69 4268	7.27 5453	8.86 6645	10.44 7830	12.03 9023	13.62 10215	15.20 11400	16.79 12593	18.37 13778	19.96 14970	21.54 16155
	66	2.77 2078	4.51 3383	6.26 4695	8.00 6000	9.75 7313	11.49 8618	13.24 9930	14.98 11235	16.73 12548	18.47 13853	20.22 15165	21.96 16470	23.71 17783
	72	3.02 2265	4.92 3690	6.83 5123	8.73 6548	10.64 7980	12.54 9405	14.44 10830	16.35 12263	18.25 13688	20.16 15120	22.06 16545	23.96 17970	25.87 19403
	78	3.24 2430	5.29 3968	7.33 5498	9.37 7028	11.42 8565	13.46 10095	15.51 11633	17.55 13163	19.59 14693	21.64 16230	23.68 17760	25.72 19290	27.77 20828
84	3.53 2648	5.75 4313	7.98 5985	12.20 9150	12.42 9315	14.65 10988	16.87 12653	19.09 14318	21.32 15990	23.54 17655	25.77 19328	27.99 20993	30.21 22658	
90	3.81 2858	6.22 4665	8.62 6465	11.03 8273	13.43 10073	15.83 11873	18.24 13680	20.64 15480	23.04 17280	25.45 19088	27.85 20888	30.26 22695	32.66 24495	
96	4.10 3075	6.68 5010	9.27 6953	11.85 8888	14.43 10823	17.02 12765	19.60 14700	22.19 16643	24.77 18578	27.35 20513	29.94 22455	32.52 24390	35.10 26325	
102	4.36 3270	7.10 5325	9.85 7388	12.59 9443	15.34 11505	18.08 13560	20.83 15623	23.57 17678	26.32 19740	29.06 21795	31.81 23858	34.55 25913	37.30 27975	
108	4.61 3458	7.51 5633	10.42 7815	13.32 9990	16.23 12173	19.13 14348	22.03 16523	24.94 18705	27.84 20880	30.75 23063	33.65 25238	36.56 27420	39.46 29595	
114	4.86 3645	7.92 5940	10.99 8243	14.05 10538	17.11 12833	20.18 15135	23.24 17430	26.31 19733	29.37 22028	32.43 24323	35.50 26625	38.56 28920	41.62 31215	
120	5.10 3825	8.31 6233	11.53 8648	14.74 11055	17.95 13463	21.17 15878	24.38 18285	27.60 20700	30.81 23108	34.20 25650	37.24 27930	40.45 30338	43.66 32745	

This Table has been developed to assist in application and selection of these louvers. Two numbers are shown for each louver size. The upper number represents the sq. ft. of louver free area for each louver size. The lower number shows CFM of air flow permitted when selecting an intake louver at the point of zero water penetration.

Pressure drop when using this selection Guide for an intake louver will be .055 in. W.G. Louvers may be selected at other operating points on the Performance Curves if desired using the formula:  
 $CFM = \text{Free Area (sq. ft.)} \times \text{Free Area Velocity (FPM)}$

# Installation Instructions

## Leader Model DC-436

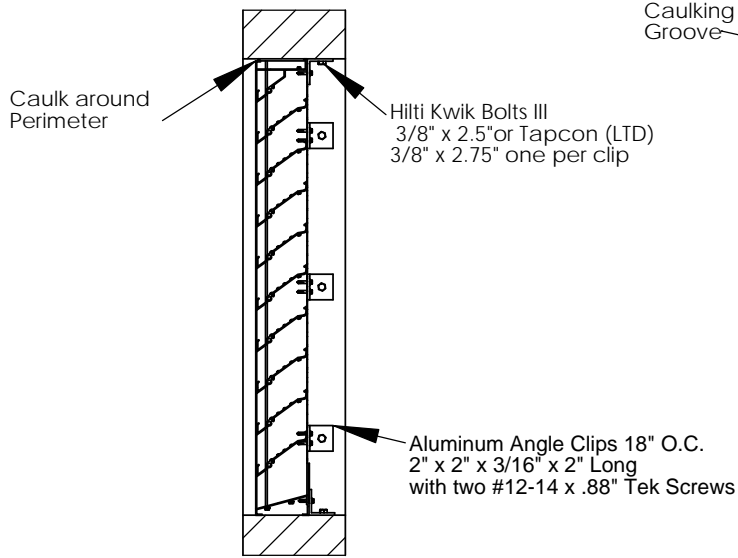

Fig. 1 - DC-436-1

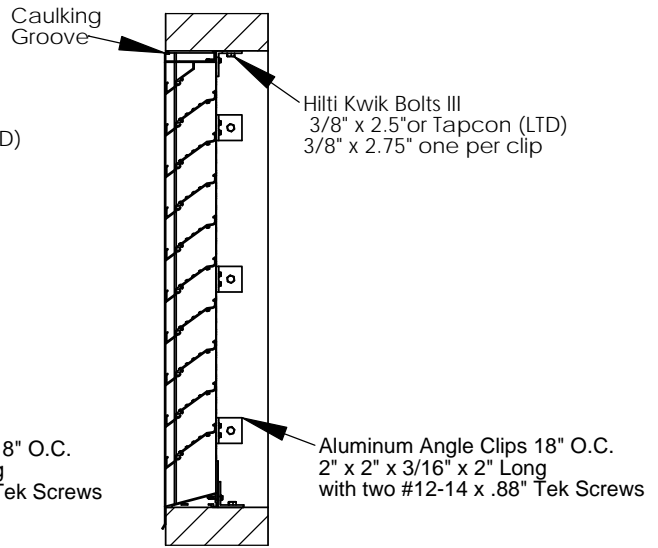

Fig. 2 - DC-436-2

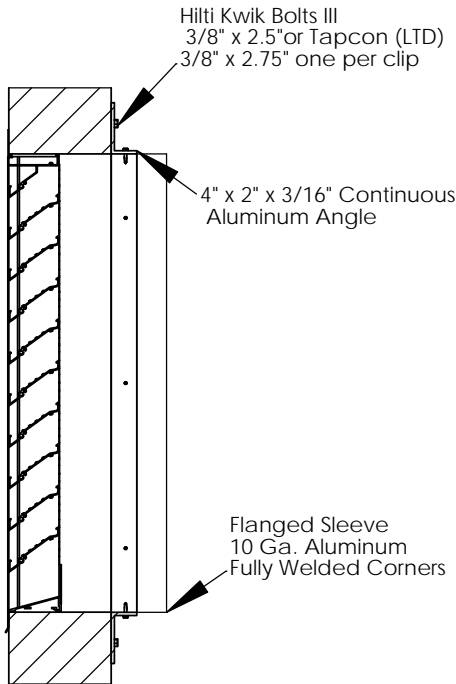

Fig. 3 - DC-436-3

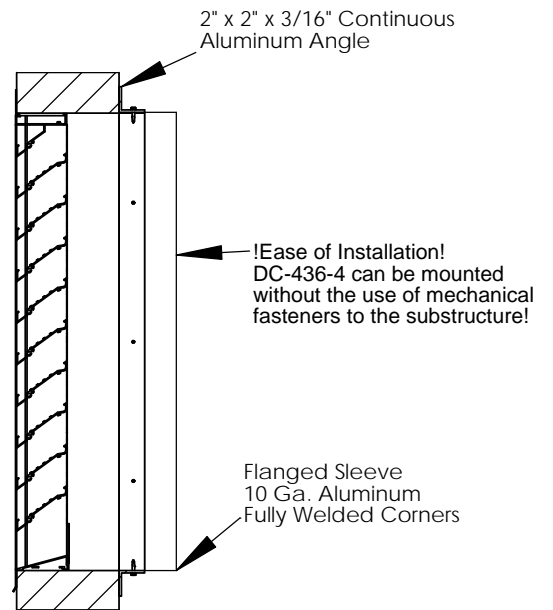

Fig. 4 - DC-436-4

See following page for installation details:

## Models DC-436-1, DC-436-2

1. **Anchoring into Concrete or Masonry:** See **Fig. 1 & 2**, Model **DC-436-1, DC-436-2** for detailed instructions.
2. Install louver into opening. Shim as required at each set of installation anchors using load-bearing shims. Max allowable shim stack to be ¼". Use shims where space greater than 1/16" is present. Fasten angle clips to DC-638-1 louver with two (2) # 12-14 x .88 TEK screws. Use 3/8" Dia. Hilti Kwik Bolt III of sufficient length to achieve min. of 3" embedment into concrete or masonry with min. 2 1/2" edge distance.
3. **Anchoring into Wood Frame Substrate:** Use 5/16" Dia. Lag Screws of sufficient length to achieve 2 ½" min. embedment into wood framing with min. 3" edge distance.
4. Seal louver opening to perimeter using backing rod and sealant (by others).  
For correct anchor spacing according to opening size, and for more detailed drawing see NOA #07-1105.04.

## Model DC-436-3

1. **Anchoring into Concrete or Masonry:** See **Fig. 3** Model **DC-436-3** for detailed instructions.
2. Install louver into opening. Shim as required at each set of installation anchors using load-bearing shims. Max allowable shim stack to be ¼". Use shims where space greater than 1/16" is present. Fasten continuous angle to DC-436-3 louver sleeve with # 12-14 x .88 TEK screws, spacing as follows: **Head and Sill** - at 8" from corners, 13" O.C. **Jambs** - at 6" from corners, 18" O.C. Attach continuous angle, (with same fastener spacing as TEK screws), to concrete or masonry using 3/8" Dia. Hilti Kwik Bolt III of sufficient length to achieve min. of 3" embedment into concrete or masonry with min. 2 1/2" edge distance.
3. **Anchoring into Wood Frame Substrate:** Use 5/16" Dia. Lag Screws of sufficient length to achieve 2 ½" min. embedment into wood framing with min. 3" edge distance.
4. Seal louver opening to perimeter using backing rod and sealant (by others). For more detailed drawings and instructions see NOA #07-1105.04.

## Model DC-436-4

1. Install louver into opening. Shim as required using load-bearing shims. Max allowable shim stack to be ¼". Use shims where space greater than 1/16" is present.
2. Attach Sleeve to the continuous angle with #12-14 x .88 TEK screws. Spacing as follows: **Head and Sill** - at 8" from corners, 13 ½" O.C. **Jambs** - at 6" from corners, 12" O.C. Hilti Kwik Bolt III or lag screws are not used for this configuration.
3. This configuration of the DC-436 Louver System is not mechanically fastened to the substrate.
4. Seal louver opening to perimeter using backing rod and sealant (by others). For more detailed drawings and instructions see NOA #07-1105.04.

## DC-436 Series Hurricane Louver Specifications

All Severe Duty Hurricane Louvers shall have been tested and successfully passed the Miami-Dade County requirements as listed below for impact resistance, static and cyclic air pressure testing as set forth by the Miami-Dade County Building Code Compliance Office and carry the appropriate NOA seal.

- A. Impact Test: TAS 201 Large Missile
- B. B. Uniform Static Pressure Test: TAS 202
- C. Cyclic Wind Pressure Load Test TAS 203 with a Specimen Design Pressure (DP) rating not less than 120 pounds per square foot.

All **DC-436** four inch deep Hurricane Louvers have been tested and certified for air performance and water penetration and are in compliance with the requirements of **AMCA** Standard 500 and carry the appropriate seal.

The **DC-436** four inch deep Hurricane Louvers is a drainable blade design utilizing integral water drains within the louver jambs to carry water away from the outer face. Louver Blades, Jamb Headers and Sills shall be constructed of a minimum .080 thick extruded 6063 T5 aluminum alloy. A .0516 thick x 3/4" flattened expanded aluminum bird screen attached to the rear of the louver shall be standard.

The **DC- 436** Mounting Method 4, four inch deep Hurricane Louvers incorporates a factory furnished sleeve (12" minimum up to a 24" maximum length) with fully welded corners constructed of a minimum of .101" thick aluminum. Sleeve to incorporate a standard formed 1.5" (2" optional) wide mounting flange located on the front side of the louver. Factory provided retaining angles are positioned on the face of the inside wall and attached to the sleeve by means of screws. No drilling of support walls or building structure is necessary to secure the louver in the prepared opening. All screws shall be caulked after installation to obtain a watertight seal.

All Severe Duty Hurricane Louvers shall incorporate factory provided weep openings in the bottom corners of the louver assembly to drain any water carry over due to excessively high wind driven rain.

### Acceptable Manufacturers

1. Leader Dampers & Louvers Model **DC- 436**, Mounting Methods 1, 2, 3 or 4 as applicable.