

Model DO-3 Control Damper Opposed Blades with Exposed Linkage

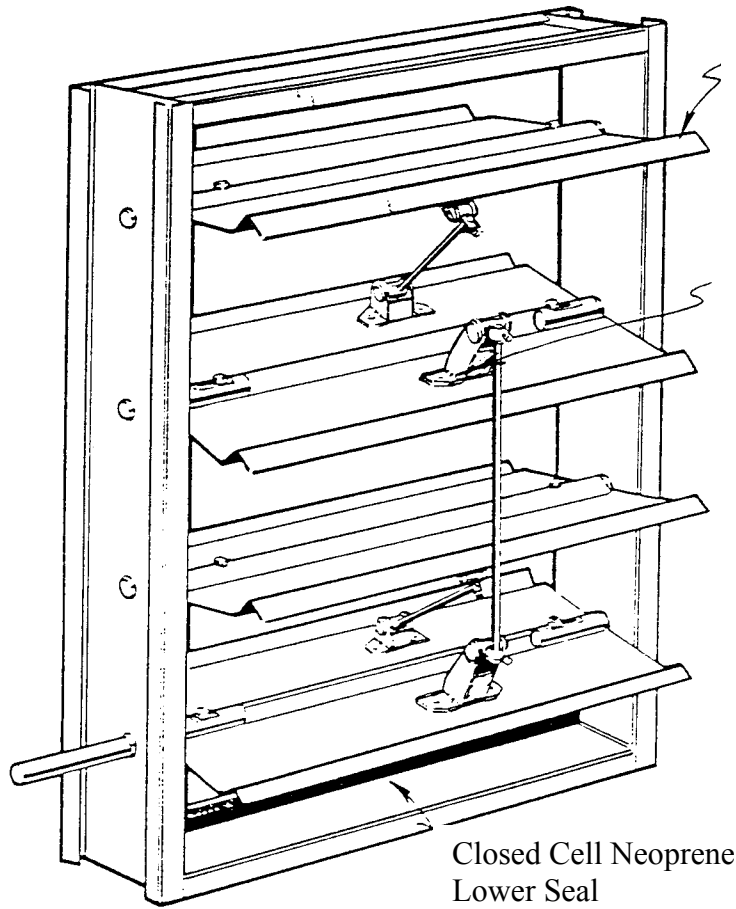

Triple Crimped Blade
for Extra Rigidity

Riveted Blade
Linkage

Closed Cell Neoprene
Upper Seal

Closed Cell Neoprene
Lower Seal

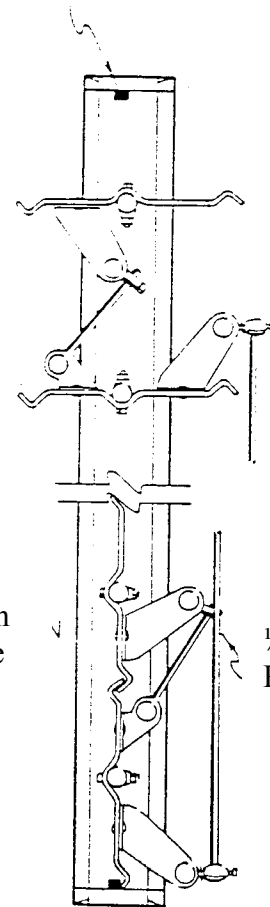

1/4" Less Than
Opening Size

1/4" Linkage
Rod

Stainless Steel Const.

Frame: 16ga. Stainless Steel 3"x3/4 channel
Blades: 16ga. S.S. triple crimp 6" on center
Linkage: Stainless with brass pivots
Bearings: 1/2 S.S.
Control Shaft: 6" long x 1/2
Minimum Size: 6"x12" (Opposed)
Maximum Size: 52"x 60"

LEADER

A Division of Leader Industries, Inc.

P.O. Box 40913
Nashville, TN 37204
www.leaderindustries.com

APPROVAL