

# Model DP-2 Control Damper Type CO, CR

Parallel Blade

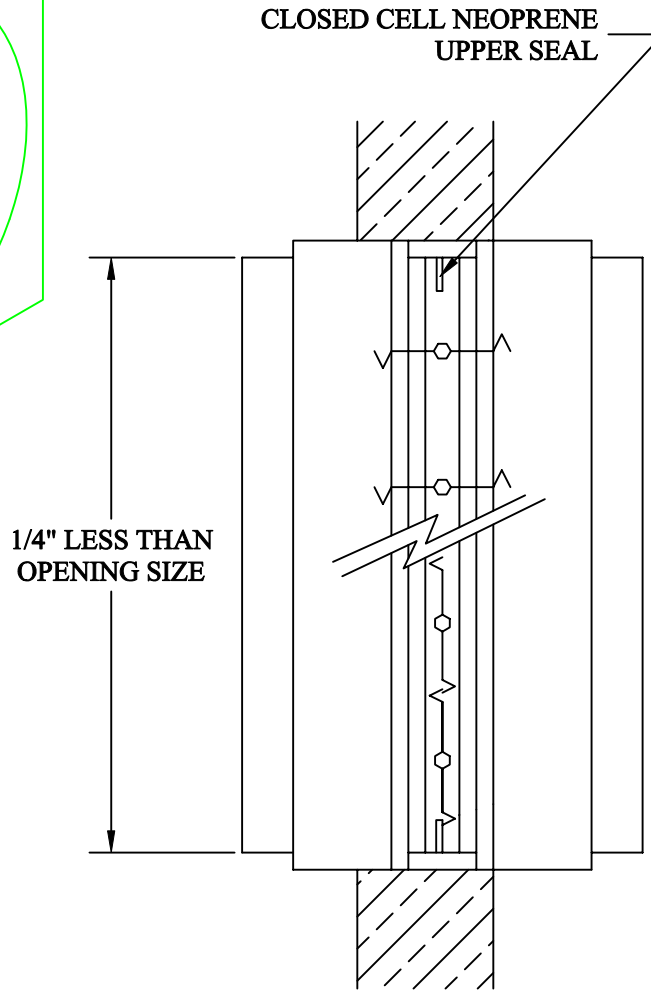
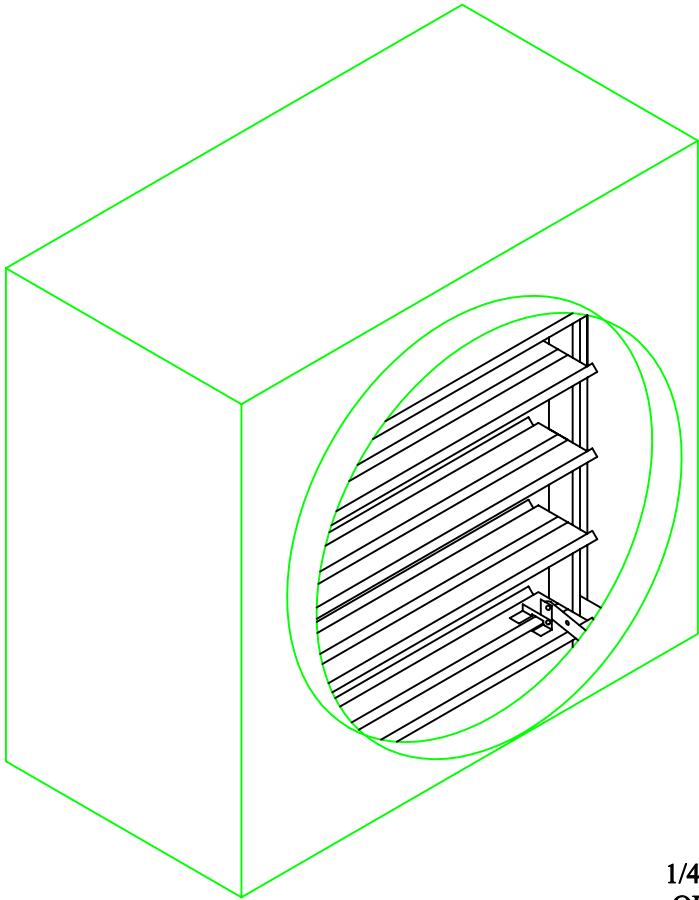

**Standard Specifications:**

- Frame: 16 ga. Galvanized steel 4-1/2" x 3/4" rollformed channel
- Blades: 16 ga. Galvanized steel, triple crimped blades are on 6" centers.
- Linkage: Concealed in jamb.
- Bearings: 7/16" ID nylon.
- Axles: 7/16" plated hex.
- Control Shaft: 3" long x 1/2" round
- Minimum Size: 6" dia.
- Maximum Size: 50" dia (single section)
- Finish: Mill Finish galvanized.

**JOB:** \_\_\_\_\_

**LOCATION:** \_\_\_\_\_ **JOB NO.:** \_\_\_\_\_

**ENGINEER:** \_\_\_\_\_ **REPRESENTATIVE:** \_\_\_\_\_

**CONTRACTOR:** \_\_\_\_\_ **DATE:** \_\_\_\_\_

**LEADER**  
Dampers & Louvers

P.O. Box 40913  
Nashville, TN 37204  
www.leaderindustries.com  
A Division of Leader Industries, Inc.

**APPROVAL:**

# MODELS DS-1, DP-2, DO-3 AIR CONTROL DAMPERS

## PERFORMANCE DATA

### Pressure Drop

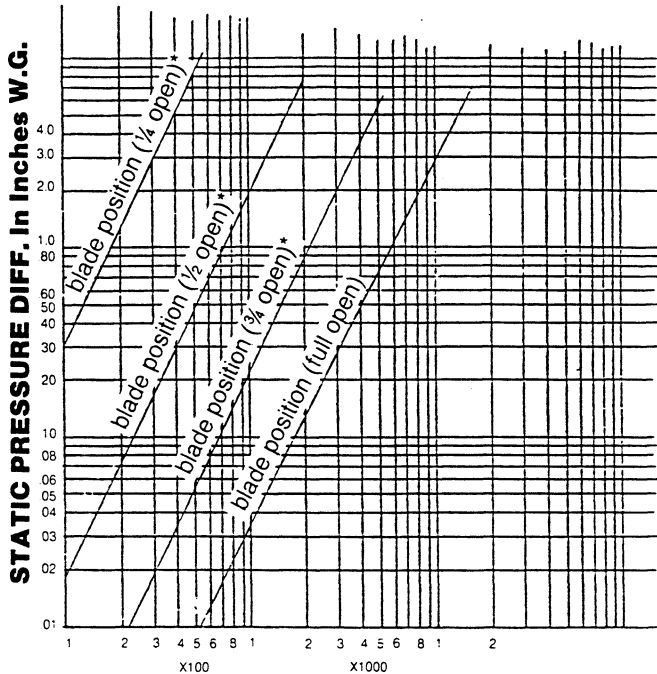

### FREE AREA

	WIDTH								
	6	12	18	24	30	36	42	48	52
6	.114	.270	.426	.582	.739	.895	1.05	1.21	1.31
12	.270	.641	1.01	1.38	1.75	2.12	2.49	2.86	3.11
18	.438	1.04	1.64	2.24	2.84	3.44	4.04	4.64	5.04
24	.606	1.44	2.27	3.10	3.93	4.76	5.59	6.42	6.98
30	.774	1.84	2.90	3.96	5.02	6.08	7.14	8.21	8.91
36	.942	2.23	3.53	4.82	6.11	7.40	8.69	9.98	10.85
42	1.11	2.63	4.16	5.68	7.20	8.72	10.24	11.77	12.78
48	1.28	3.03	4.78	6.54	8.29	10.04	11.80	13.55	14.72
54	1.45	3.43	5.41	7.40	9.38	11.36	13.35	15.33	16.65
60	1.62	3.82	6.04	8.26	10.47	12.68	14.90	17.11	18.59

Free Area is calculated by subtracting blades, frame, and/or linkage from the duct area.

### VELOCITY F.P.M.

The tables have been developed through tests done at an independent testing laboratory to assist in application and selection of air control dampers. Performance shown is at standard air density of .075 lb/ft<sup>3</sup>.

These dampers have been tested and operated at 2500 FPM at 4" S.P. If conditions exceed specified velocity or pressure, consult factory.

Pressure drop test are based on AMCA standard 500 using test set-up figure 5.3 for dampers installed with duct upstream and downstream.

Dampers with the same percent of free area (Actual free area divided by Duct free area x 100) will have approximately the same pressure drop. The percent of free area is proportional to its pressure loss and can be interpolated using the reference point of the 24" wide by 24" high at a given airflow.

\*Model DO-3 (Opposed Blade)

### TEST SIZE 24"x24"

### Air Leakage

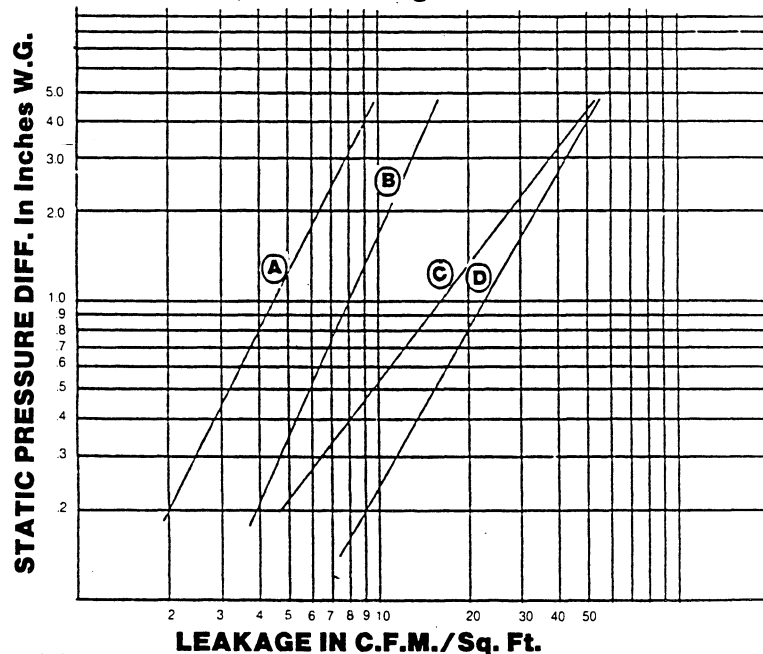

### Air Leakage

- A. Leakage of the damper with stainless blade and jamb seals.
- B. Leakage of the damper with silicone blade and aluminum jamb seals.
- C. Leakage of the damper with aluminum jamb seals only.
- D. Leakage of the damper with blade seals only.



A Leaders Industries Division