

Model: BDA-HU Backdraft Damper

Horizontal Mount, Vertical Airflow Up

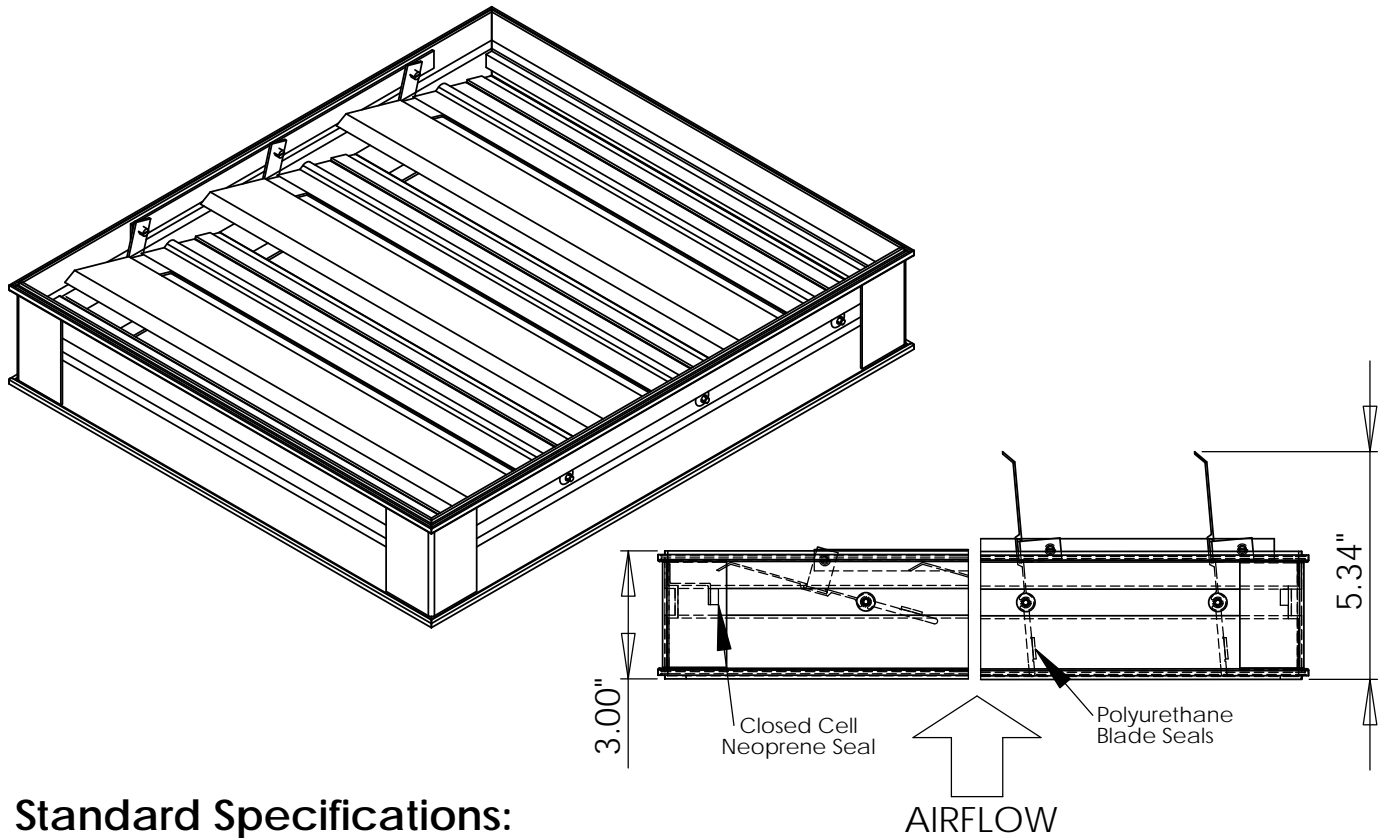

Standard Specifications:

- Frame: .070" Extruded Aluminum
6063-T5 Alloy, Mitered Corners
- Blade: .050" Extruded Aluminum 6063-T5
Alloy with Polyurethane Seals
- Bearings: .25" ID Nylon
- Axles: .25" Nylon
- Minimum Size: 6" w x 6" h
- Maximum Size: 36" w x 48" h

Optional Features:

- Flange Upstream (1.5")
- Flange Downstream (1.5")
- Counter-Balanced
- Birdscreen
- Insect Screen
- Electric Operator

Options

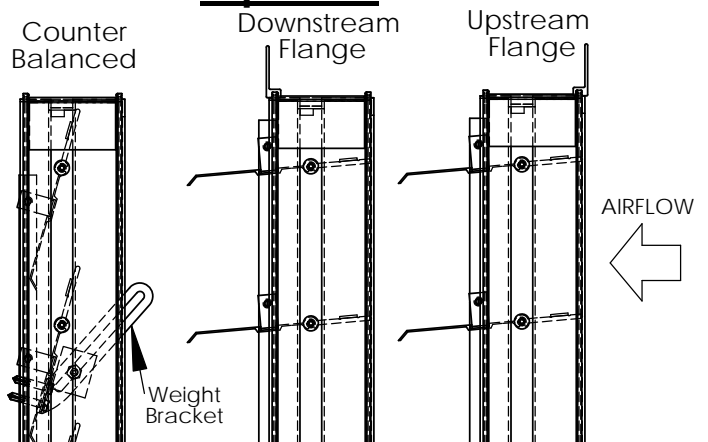

Note: All BDA dampers are built 1/4" under size in both directions unless ordered actual size

JOB: _____
 LOCATION: _____ JOB NO: _____
 ENGINEER: _____ REPRESENTATIVE: _____
 CONTRACTOR: _____ DATE: _____



P.O. Box 40913
 Nashville, TN 37204
 www.leaderindustries.com
 A Division of Leader Industries, Inc.