

DUCT SMOKE DETECTOR

PURPOSE/APPLICATION:

National and local safety standards and codes recognize the ability of air duct systems to transfer smoke, toxic gases, and flame from area to area. Sometimes smoke can be of such quantity as to be a serious hazard to life safety unless blowers are shut down and dampers are actuated. The primary purpose of duct smoke detection, then, is to prevent injury, panic, and property damage by reducing the spread or recirculation of smoke. Duct smoke detection can also serve to protect the air conditioning system itself from fire and smoke damage. When presence of smoke in the duct is sensed, or when loss of power occurs, the damper will fail close. Consult NFPA90A, NFPA72 documents and local codes to determine where smoke detectors are required.

FEATURES:

1. Low-Flow Technology: Both Ionization & Photoelectric models listed for velocities between 100-4000 ft/min.
2. Interconnect up to 30 units for common functions.
3. Flashing LED on detector head indicates normal operation.
4. Rest switch is also an alarm test switch.
5. Two sets of 10A form "C" alarm contacts.
6. One set of 10A form "C" trouble contacts.
7. Interchangeable "Plug-In" Photoelectric or Ionization heads
8. Clear cover for convenient visual inspection
9. #14 to #22 AWG terminals
10. Unit has green pilot and red alarm visual indicators.

AVAILABILITY:

For use on all 500 & 600 series Fire/Smoke Combinations
All SMD & ASMD Smoke Dampers

The Smoke Detector is not rated for use at velocities below 100 fpm, local code may require an alternate means of damper closure such as Zone detection or automated damper closure when the system fan is shut down. The local authority having jurisdiction should be consulted prior to the installation of the damper and smoke detector.

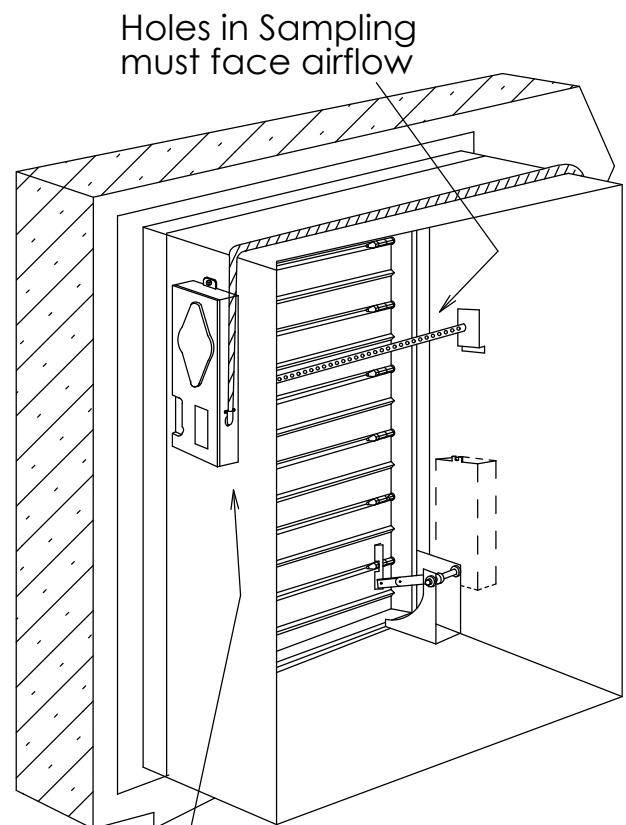

Duct Smoke Detector
Model SL-2000

LEADER
Dampers & Louvers

P.O. Box 40913
Nashville, TN 37204
www.leaderindustries.com
A Division of Leader Industries, Inc.

SPECIFICATIONS:

Type: Photoelectric or Ionization

Air Duct Velocity: 100 fpm minimum

Operating Temperature Range: Model SL-2000-N 32 F to 155 F (0 C to 70C)
Model SL-2000-P 32 F to 100 F (0 C to 38 C)

Operating Humidity Range: 10% to 85% R.H. No Condensation

Operation Voltage: 230VAC, 115VAC, 24VAC, 24VDC

CONFIGURATIONS:

500 Series & 600 Series wall thickness: over 6" Consult Factory

Actuator Location: Must be external mount

Detector Location: Mounts opposite actuator side

Dampers under 16" tall must have 26" minimum length sleeve

Sampling tubes longer than three (3) feet must be supported on each end.
Holes in duct smoke detector sampling tubes must face the airflow.

*Refer to the smoke detector manufacturer's installation instructions if more information is needed.

MAINTENANCE:

Each installation location must be assessed on its own merits. If the protected duct is of a very dirty nature then the SL-2000 Detectors will have to be checked and cleaned on a Quaterly bases or when cleaning is required. As a guideline the detector head should be cleaned every six months or as required, as per NFPA 72. The best methods of cleaning are to vacuum the detector head thoroughly or to blow the detector head out using clean, dry compressed air. Do not use chemicals to clean the detector head housing as this could contaminate the detector head and damage the casing. Sampling and exhaust tubes must be inspected and cleaned in accordance with the schedule as determined above, to allow the free flow of air through the sampling tube.

POWER REQUIERMENTS (Without Accessories):

STANDBY CURRENT

24VAC	39.4mA
24VDC	13.5mA
115VAC	13.8mA
230VAC	7.9mA

ALARM CURRENT

24VAC	128.7mA
24VDC	59.3mA
115VAC	27.0mA
230VAC	16.0mA

Damper Less Than 16" High

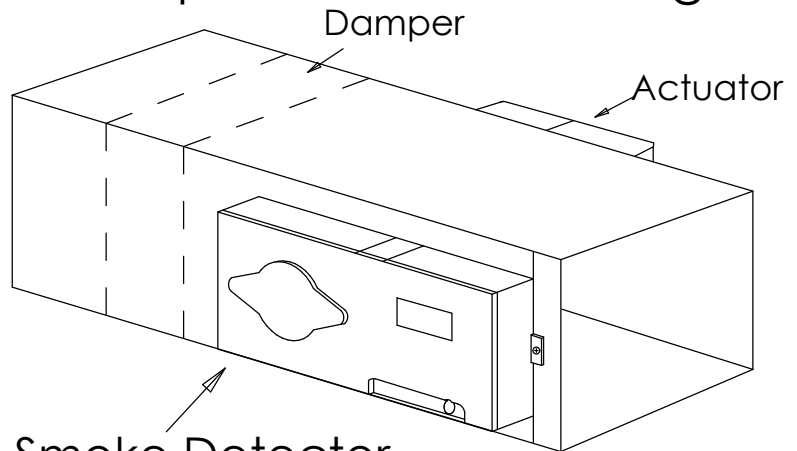

Duct Smoke Detector
mounts opposite actuator side of damper

LEADER
Dampers & Louvers

P.O. Box 40913
Nashville, TN 37204
www.leaderindustries.com
A Division of Leader Industries, Inc.

Fuse Link

Duct Smoke Detector
WIRE DIAGRAMS

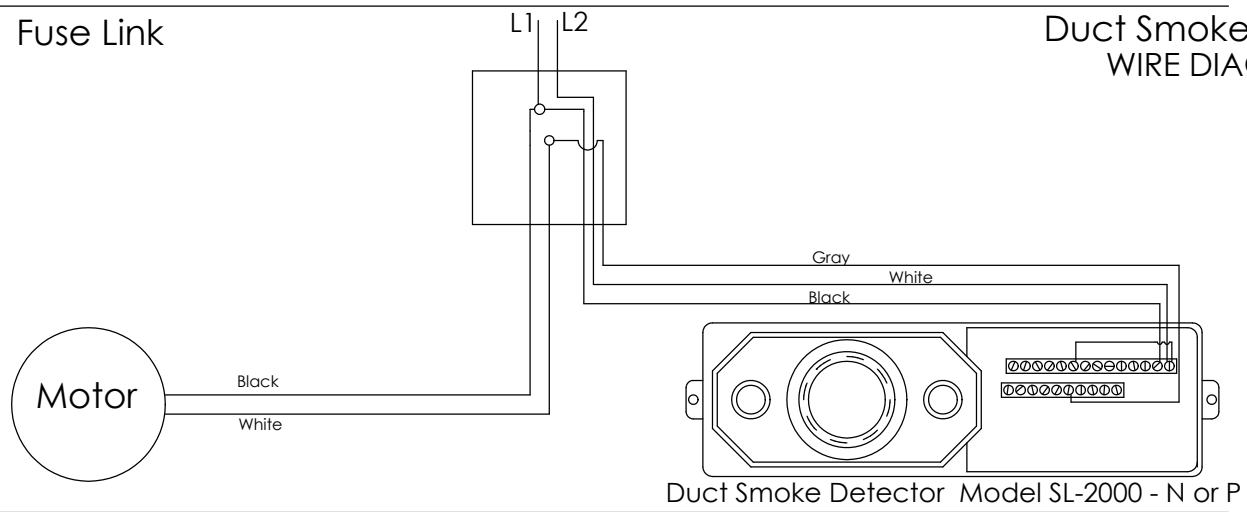

STD with BIP

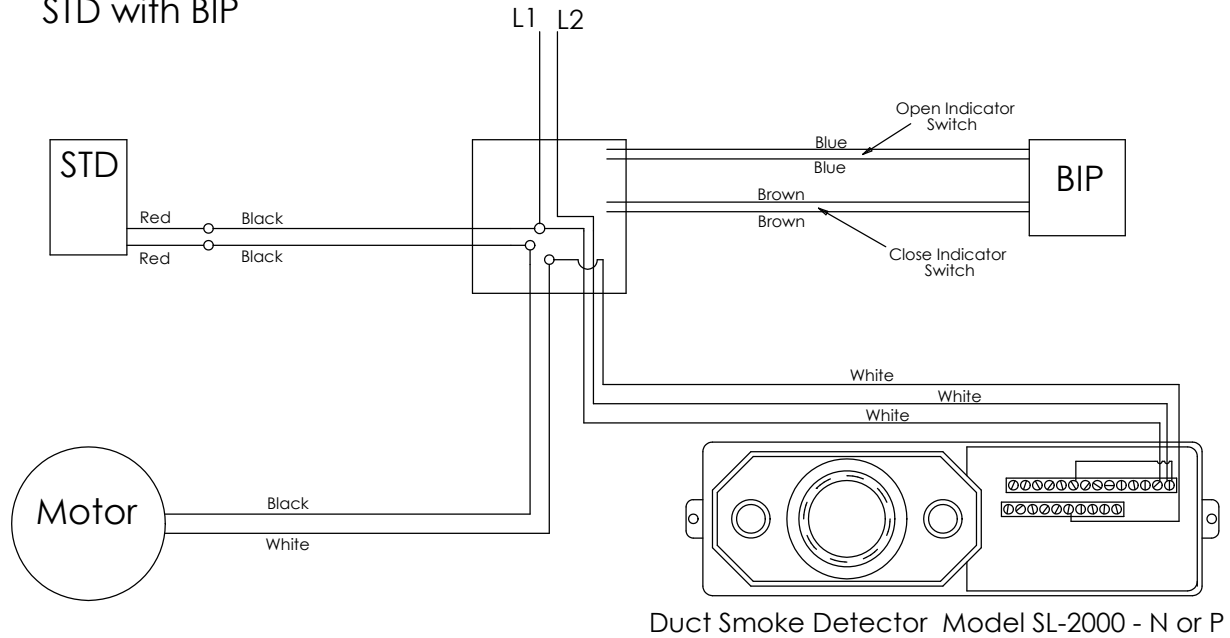

TTD with BIP

