

# Powers™ Controls

## Three-way Electro-pneumatic (EP) Valve Model 2

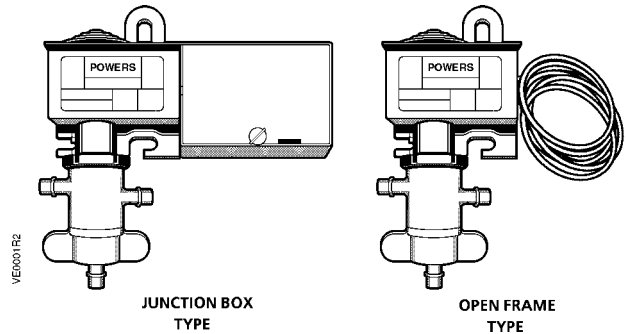

### Description

The VE 265 Electro-Pneumatic Valve is a general purpose, electrically operated, two-position 3-way valve designed to control air flow. It can be used for interlock between an electrical system and a pneumatic control system.

This compact, lightweight air valve has barbed, plastic tube connections marked:

- 1 - Normally closed
- 2 - Normally open
- 3 - Common

Available types are Open Frame (yoke) and Junction Box (splice box).

### Features



- UL and CSA approved for general purpose
- Valve may be mounted in any position
- Mounting holes provided in the yoke
- Wide selection of AC voltages

### Product Numbers

Table 1.

Product Enclosure Type	AC Voltage		Product Number
	60Hz	50Hz	
Junction Box	24	—	265-1001
Junction Box	120	110	265-1002
Junction Box	208	—	265-1003
Junction Box	240	220	265-1004
Junction Box	277	—	265-1005
Junction Box	480	440	265-1006
Open Frame	24	—	265-1007
Open Frame	120	110	265-1008

## Warning/Caution Notations

<b>WARNING:</b>		Personal injury/loss of life may occur if a procedure is not performed as specified.
<b>CAUTION:</b>		Equipment damage, or loss of data may occur if the user does not follow procedure as specified.

## Specifications

Material:	
Body	Celcon plastic
Internal	Buna N, copper, Stainless Steel
Ambient Temperature:	
Junction Box Type	0°F to 100°F (0° to 38°C)
Open Frame Type	0°F to 110°F (0° to 43°C)
Control Fluid	Air Only
Max. Air Pressure	30 psig (207 kPa)
Airflow Capacity:	
Airflow	600 SCIM (164 ml/s)
@ Inlet Pressure	20 psig (138 kPa)
@ Differential Pressure	1 psig (7 kPa)
Cv Flow Factor	0.06 in <sup>2</sup>
Electrical Ratings:	
Voltages	24 to 480 Vac
Power consumption	5.7 Watts
Current drain	Inrush 17.3 VA Holding 9.2 VA
Mounting bracket has:	1 oval and 1 open-ended hole; it is part of the yoke.
Air Connections	Barbed fittings for 1/4-inch (6.4 mm) OD plastic tubing
Shipping Weight	
Open Frame Type	0.37 lb. (0.17 kg)
Junction Box Type	0.54 lb. (0.24 kg)
Dimensions	See <i>Figure 2</i>

## Application

These valves are commonly used to alternately apply pressure to, and exhaust pressure from, pneumatically controlled devices (valves, damper actuators) by an electrical input energizing or de-energizing the solenoid of the valve.

A standard method is shown in *Figure 1*. The input air is connected to Port 1 (normally closed), and the output is connected to Port 3 (common). When the solenoid is energized, Port 1 connects to Port 3 permitting the thermostat to control the damper actuator. When the solenoid is de-energized, Port 2 (normally open) is connected to Port 3 exhausting air from the actuator permitting it to return to its normal position.

Other valves can be provided to meet specific OEM requirements. Contact National OEM Sales for information.

**Application,  
 Continued**

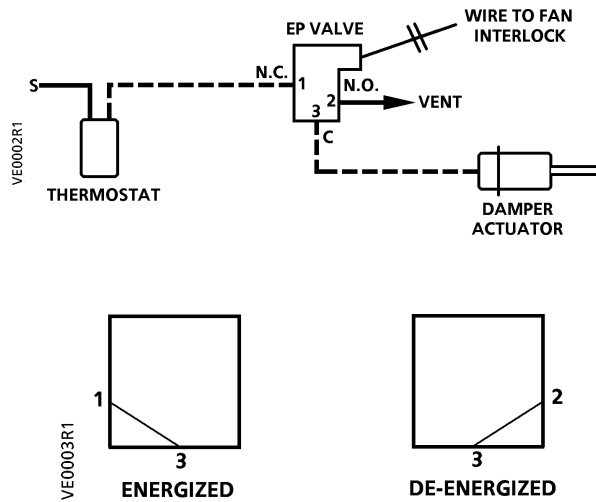

**Figure 1. Standard Application.**

**Installation**

These valves are designed for either wall mounting or panel mounting and may be mounted in any position. The coil and enclosure may be rotated 360° in relation to the body, if necessary. Make certain there is sufficient space around the valve for ease of future servicing. These valves require no adjustment or calibration.

**General**



**CAUTION:**

Be sure power is off during installation and servicing.

**NOTE:** Media filtration—although these valves have no sliding parts and are generally not sensitive to small amounts of foreign material, filtration of oil and dirt from air line is recommended. Dirt or foreign material in the media may cause excessive leakage, excessive wear or, in exceptional cases, malfunction. Lubrication is not required.

**Air Connections**

All pneumatic piping connections are sized for 1/4-inch (6 mm) O.D. polyethylene tubing. The connections are sharp, barb-type connections.

**Electrical Connection**

Electrical supply must conform to nameplate rating. Connect coil leads to electrical circuit using standard electrical practice. Wiring connections on the junction box models are made via splices inside the box. Knock-outs are provided in the box. Grounding screw is provided at rear of box.

Wire leads provide a means of connection on the open frame models. Use standard wire nut connectors when making these connections (not included).

**Wall Mounting  
 (Junction Box Type)**

If the valve is to be wall mounted, holes must be drilled for the mounting screws (not included). Drill holes for No. 8 screws. Either the mounting holes in the yoke or the knock-out mounting holes on the inside of the splice box may be used.

**Panel Mounting  
 (Open Frame Type)**

Panel mounting the valve is similar to wall mounting the device. Line up the No. 8 mounting holes and slot in yoke with holes in the panel or drill new holes. Attach the valve to the panel using mounting screws (not included).

**Coil Housing  
 Temperature**

Standard valves are supplied with coils designed for continuous duty service. Normal free space must be provided for proper ventilation. When the coil is energized continuously for long periods of time, the coil housing will become hot. The coil is designed to operate permanently under these conditions.

## Troubleshooting

**Table 2. Troubleshooting.**

Problem	Procedure
Valve fails to operate	1. Check electrical supply with voltmeter. 2. Check coil with ohm meter for short or open coil. 3. Check pressure line for dirt.
External leakage	Replace valve.
Internal leakage	Standard valve design permits 40 cc/min. max. @ 50 psi
Noise or buzzing	Check voltage with voltmeter to be sure it corresponds with nameplate rating. Also check pressure for same.

## Service

Replacement coils are the only replacement parts available. For replacement part numbers, see *Service Parts*.

### Coil Replacement

Since the body and sleeve are permanently staked together, only the coil can be replaced. The procedure to replace a coil is as follows:

1. Disconnect coil from electrical service.
2. Remove air pressure.
3. Remove top clip and pull coil off.
4. Put new coil on and replace clip.
5. Connect electrical service and air pressure.

## Service Parts

**Table 3. Service Parts.**

Current Products	
E.P. Product Number	Repair Coil (pkg. 3)
265-1001	265-060
265-1002	265-061
265-1003	265-062
265-1004	265-063
265-1005	265-064
265-1006	265-065
265-1007	265-060
265-1008	265-061

**Dimensions**

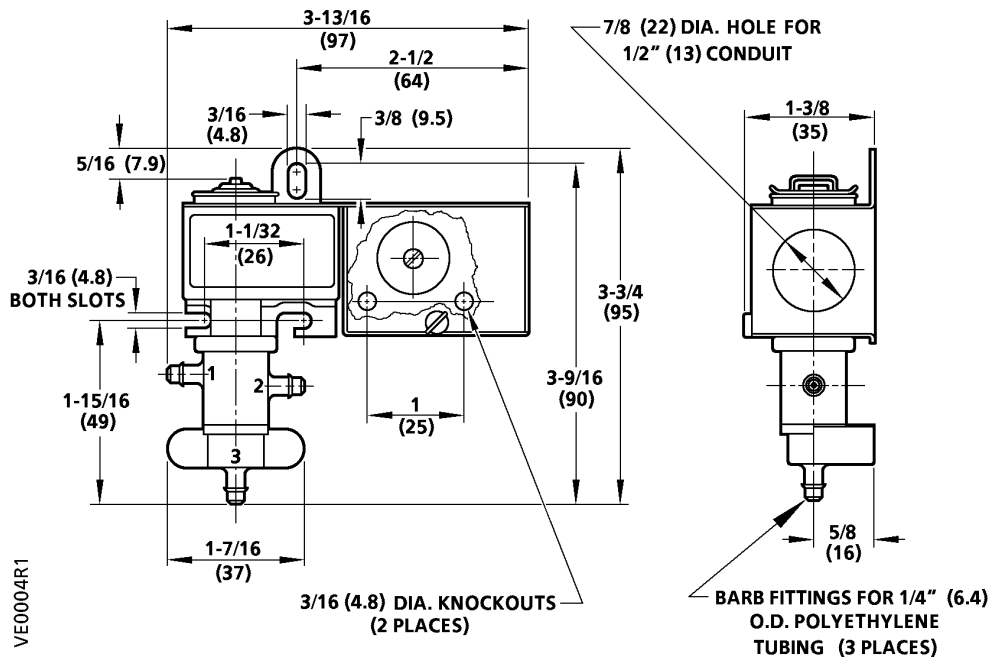

**Figure 2. Dimensions in Inches (Millimeters).**

Information in this publication is based on current specifications. The company reserves the right to make changes in specifications and models as design improvements are introduced. Powers is a trademark of Siemens Building Technologies, Inc. © 2000 Siemens Building Technologies, Inc.