

Dynamic U.L. Approved Model D-505 UL 555S

Dynamic Fire Damper - Type A

Standard Specifications:

- Frame: 16 ga. galvanized steel
- Blade: 16 ga. galvanized steel triple crimped blades are on 6" centers
- Seals: Stainless jamb
- Linkage: Concealed in jamb
- Bearings: 1/2" oilite bronze
- Axles: 1/2" plated hex
- Control shaft: 1/2" round
- Fusible Link: 212 F standard, other UL listed links optional
- Finish: Mill finish galvanized
- Minimum Size: 8"w x 8"h
- Maximum Size: Single Section 36"w x 53"h
- Maximum Size: Multiple Section 72"w x 53"h

Options:

1. Sleeve lengths: 12" to 30" wide
2. Hand Quadrant

California State Fire
Marshal Listed



3225-273:106

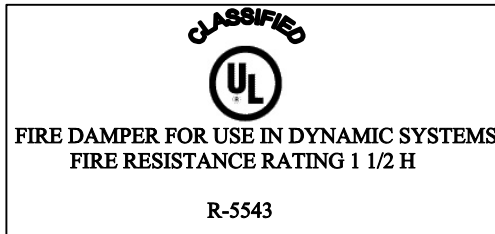
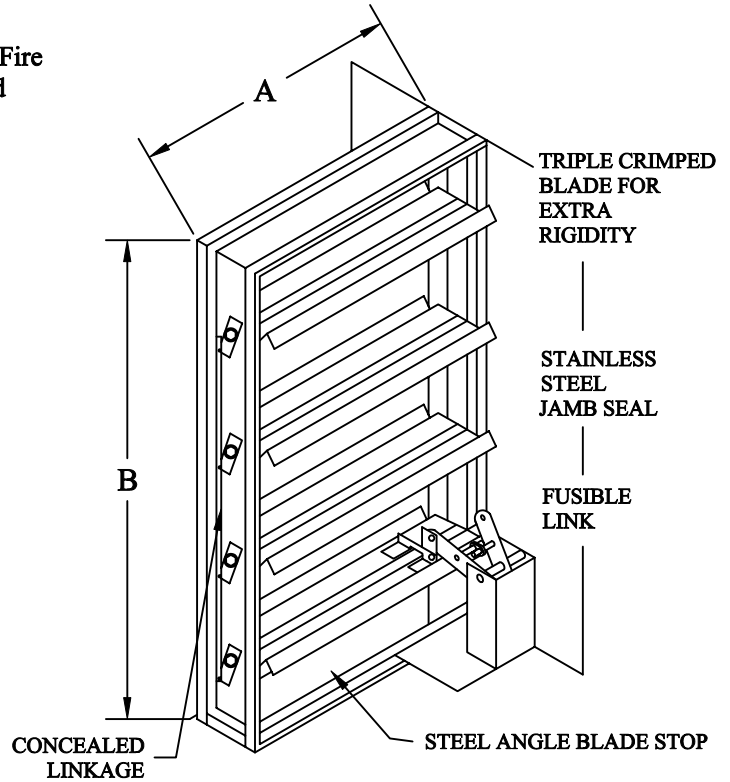

Notes:

- For proper operation all dampers must be installed square and free from racking
- Units furnished approximately 1/4" smaller than given "opening dimensions"
- Units are approved for velocities up to 2000 fpm at 4" wg static pressure.
- Units are approved for static or dynamic systems.
- This unit is UL Listed for 1-1/2 hours fire rating.
- The damper meets or exceeds the requirements of NFPA 90A, U.L. Standard 555, and complies with NFPA Bulletin 80.
- A dynamic system is one in which the fan/system continues to run during a fire/smoke alarm for smoke removal.

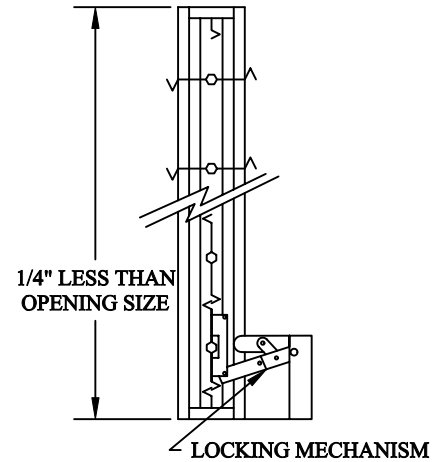

JOB: _____

LOCATION: _____ **JOB NO.:** _____

ENGINEER: _____ **REPRESENTATIVE:** _____

CONTRACTOR: _____ **DATE:** _____



P.O. Box 40913
Nashville, TN 37204
www.leaderindustries.com
A Division of Leader Industries, Inc.

APPROVAL:

Model 505 - Fire Damper Performance Data

- A. Type "A" 500 series fire / smoke combination damper
- B. Type "C" (100% free Area) 500 series fire / smoke combination damper

Pressure Drop Test Size is 24" x 24" and 36" x 36" duct opening.

These tables have been developed through tests done at an independent testing laboratory to assist in application and selection of air control dampers. Performance shown is at standard air density of .075 lb/cu. ft.

These dampers are approved for velocities up to 2000 fpm at 4 inches w.g. static pressure. If conditions exceed specified velocity or pressure, consult factory.

Pressure drop tests are based on AMCA Standard 500 using test set-up figure 5.3 for dampers installed with duct upstream and downstream.

Dampers with the same percent of free area (actual free area divided by duct free area x 100) will have approximately the same pressure drop. The percent of free area is proportional to its pressure loss and can be interpolated using the reference point of 24" wide by 24" high a given airflow.

Unit must be installed square and free from racking.

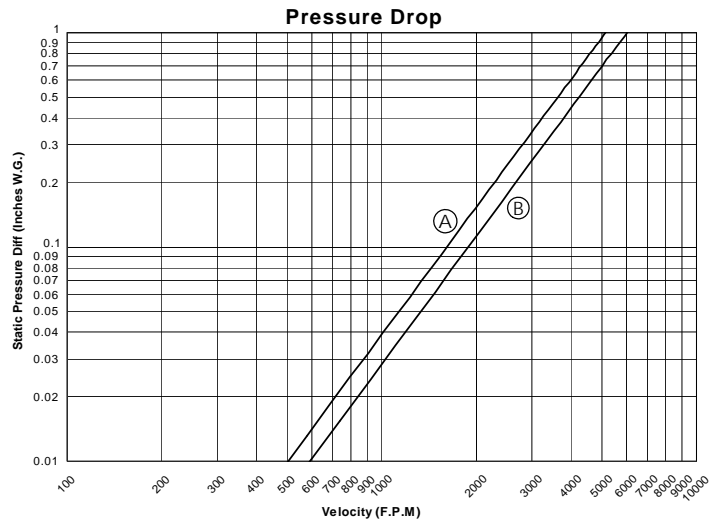

FREE AREA Type 'A' Dampers Width

	8	12	16	20	24	28	32	36	40	44
8	0.21	0.37	0.53	0.68	0.85	1.01	1.17	1.34	1.37	1.53
12	0.33	0.56	0.79	1.02	1.25	1.49	1.72	1.95	2.03	2.29
16	0.45	0.76	1.08	1.38	1.71	2.01	2.32	2.63	2.76	3.07
20	0.68	1.13	1.59	2.04	2.49	2.94	3.39	3.84	4.06	4.52
24	0.83	1.35	1.90	2.43	2.97	3.51	4.05	4.59	4.87	5.40
28	0.95	1.56	2.18	2.80	3.42	4.03	4.65	5.27	5.59	6.82
32	1.17	1.93	2.69	3.45	4.21	4.97	5.73	6.48	6.90	8.42
36	1.31	2.16	3.01	3.85	4.70	5.55	6.39	7.24	7.71	9.40
40	1.44	2.37	3.29	4.22	5.14	6.07	7.00	7.92	8.43	10.28
44	1.67	2.74	3.81	4.87	5.94	7.00	8.07	9.13	9.74	11.87
48	1.81	2.97	4.12	5.27	6.43	7.58	8.74	9.89	10.55	12.86
52	1.94	3.17	4.41	5.64	6.87	8.10	9.34	10.57	11.28	13.74

Free Area is calculated by subtracting blades, frame, and/or linkage from the duct area.



P.O. Box 40913
Nashville, TN 37204
www.leaderindustries.com
A Division of Leader Industries, Inc.

INSTALLATION INSTRUCTIONS

MODEL D-505

FIRE DAMPER

VERTICAL AND HORIZONTAL MOUNT

APPLICATION: These installation instructions are for floor/ceiling, wall or fire partitions constructed of masonry or concrete. Additional instructions for gypsum/wallboard will be provided upon request. Combination Fire and Leakage Rated Dampers are designed to operate with blades running horizontally and must be installed within the fire partition opening. To ensure optimum operation and performance, the damper must be installed so that it is square and free from racking. Do not compress or stretch the damper frame into the duct or opening. Installation must be performed in accordance with **NPFA 90A, local and national codes.**

NOTE: Maximum U.L. Listed single section damper is 36" x 48", maximum multiple section damper is 72" x 48". Unit furnished approximately **1/4" smaller** than given "opening" dimensions without sleeve. For proper operation, all dampers must be installed square and free from racking. These devices are to be arranged to operate automatically.

GENERAL INSTALLATION: The fire barrier opening shall be a minimum of 1/8" per foot larger than the overall size of the damper and sleeve assembly. The maximum opening size is **not to exceed 1/8" per foot, 1" maximum**, nor shall the opening be less than 1/4" larger than the damper or sleeve assembly. As described in **NPFA 90A** and as defined by the appropriate **SMACNA duct construction standard**, the sleeve gage shall be equal to or heavier than the gage of the duct when one or more of the following connections are used: plain s-slip, hemmed s-slip, standing s-slip, reinforced standing s-slip, inside slip joint, and double s-slip. The damper is fastened to the sleeve with 1/2" welds spaced 6" center to center. If any duct-damper connections are used other than the ones previously described, a separate sleeve must be fabricated as follows. The maximum thickness for a sleeve shall be .138" for coated steel (.135" uncoated), also it must be at least .056" thick for coated steel (.053" for uncoated) for dampers not exceeding 36"w x 24"h. For dampers larger than these dimensions, the sleeve must be at least .070" thick for coated steel (.067" for uncoated). The connecting ducts shall not be continuous, but shall terminate at the sleeve or frame. Damper sleeve shall not extend beyond the fire wall more than 6" on one side and 16" on the opposite side for access doors.

RETAINING ANGLES: Mounting angles shall be a minimum 1.5" x 1.5" x 16-gage for all sizes. They shall be fastened with #10 bolts or screws, 3/16" diameter steel rivets or 1/2" tack welds. Fasteners should be spaced 6" on center, staggered intermittently on both sides of the damper. Angles must overlap structure opening a minimum of 1" and can be attached at the corners of sizes up to 36" x 36".

ITEM DESCRIPTION

- | | |
|----|-------------------------|
| 1 | Fire Wall |
| 2 | Duct |
| 3 | Sleeve |
| 4 | Fusible Link |
| 5 | Control Shaft |
| 6 | Operator/Actuator |
| 7 | Damper Frame |
| 8 | Caulking Material |
| 9 | S-Joint, Sleeve to Duct |
| 10 | Retaining Angles |

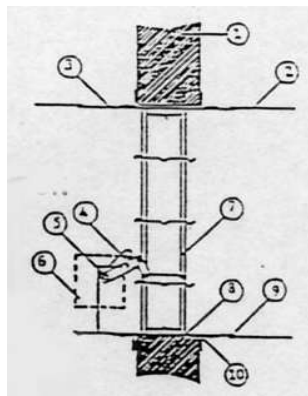

These instructions comply with Underwriters Laboratories Safety Standards 555 and 555S.

D-505dynamic-install 2003.12.06