

418/318 Motor Mount Detail

MOTOR FIELD MOUNTED OUTSIDE DUCT

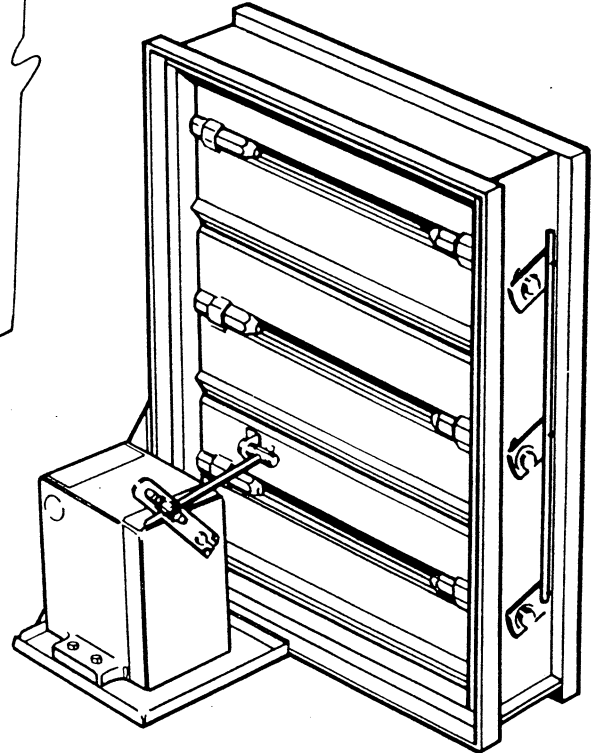
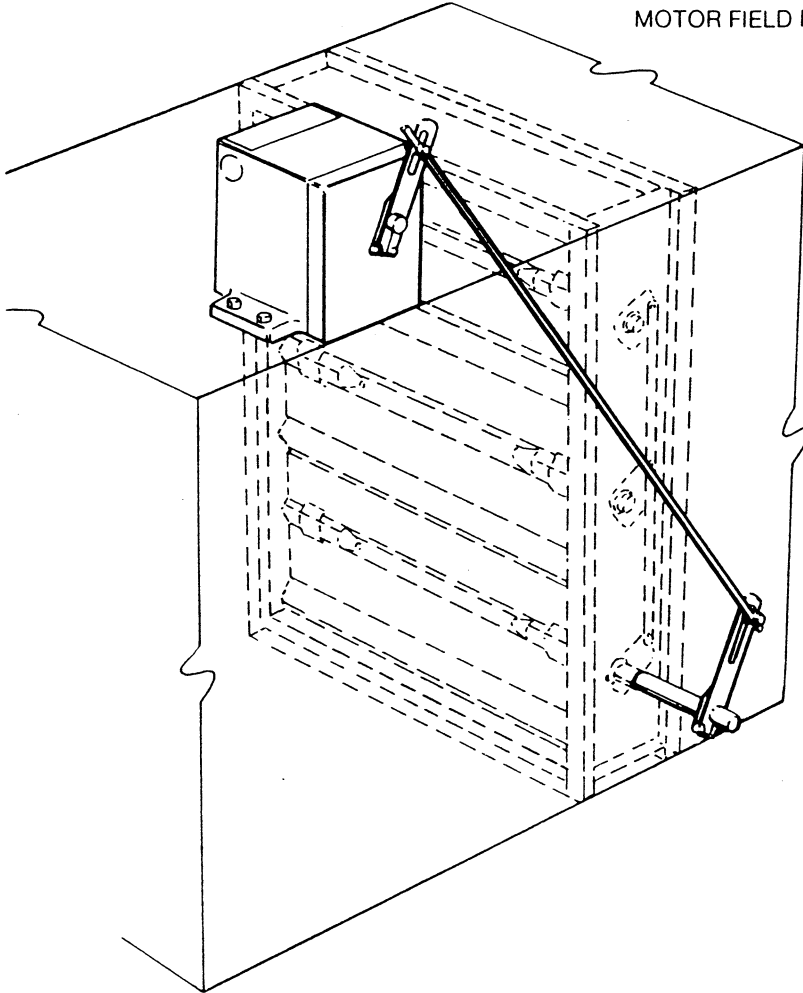

MOTOR FACTORY MOUNTED INSIDE DUCT

Typical motor mount, linkage and installation for standard 2-position spring return, power-open power-close motors. Dampers greater than 104" wide require jack shafts. On units with jack shafts the motor is connected directly to the jack shaft rather than the blade.

NOTE: The motor specifications listed below are not applicable to dampers with jamb seals. 2-position spring return motor for 32 sq. ft. max. damper face area. (Barber Coleman MA-418 110 VAC, and MA-318 24 VAC.)

JOB _____

LOCATION _____ JOB NO. _____

ENGINEER _____ REPRESENTATIVE _____

CONTRACTOR _____ DATE _____

418MM5-1990